

Clamp Thimble KK-100

Product information



A combination of wire rope clamp and thimble, approved for application in elevators and hoists. Two part thimble and recessed bolts, for easy mounting.

... [Read more](#)

Material: Cast steel GS-60. Bolts and nuts in grade 8.8.

Finish: Hot dip galvanized.

Note: Before tightening the nuts, be sure that the steel wire rope is tight in the thimble groove.

Clamp Thimble KK-100

Blueprint

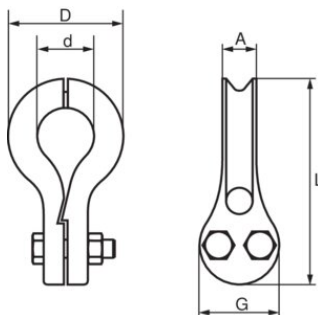

Technical data

Part code	Rope Ø range mm	A mm	D, mm	dmm mm	G, mm	L mm
123100600100	5-6	12	36	16	26	74
123100950100	7-9.5	18	54	24	40	104
123101250100	10-12.5	25	74	30	58	144
123101650100	13-16.5	28	95	40	72	190
123102000100	17-20	37	166	68	80	244